

4

3

2

1

NOTES: UNLESS OTHERWISE SPECIFIED

- 1. A (REF) DIMENSION IS FOR INFORMATION PURPOSES ONLY AND NO TOLERANCE IS IMPLIED.
- 2. AVAILABLE IN BLACK OR CHROME

REVISION HISTORY			
REV	DESCRIPTION	DATE	APPROVED
A	OUTLINE DIMENSIONAL DRAWING RELEASED	7/19/2017	CV

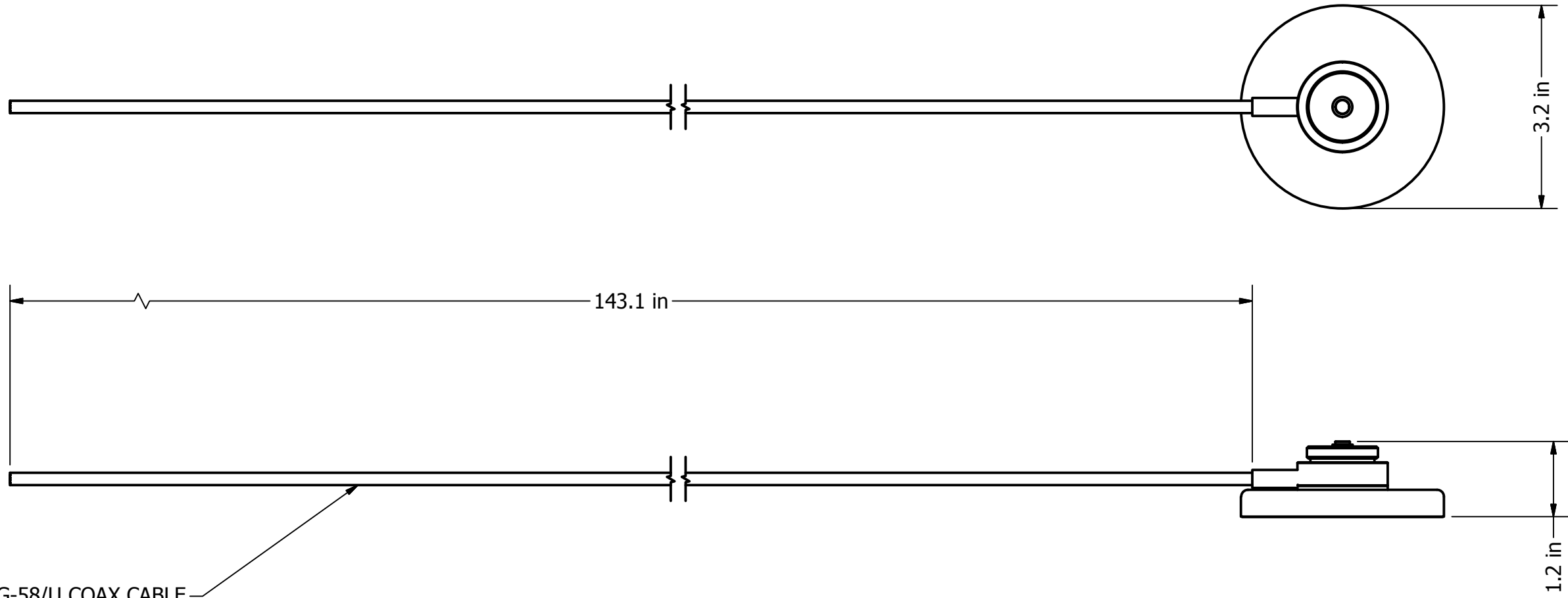

RG-58/U COAX CABLE

SUPPLIER PRINT ACCEPTANCE:

Accept drawing/specification: No changes needed:

This part is RoHS compliant

This part is REACH compliant

Accept drawing/specification. Notes/Mark-ups added

Cannot accept drawing/spec. Notes/Mark-ups added

Supplier Projected Outgoing Quality:

SIGMA LEVEL : \_\_\_\_\_ or PPM: \_\_\_\_\_

Signature \_\_\_\_\_ Date: \_\_\_\_\_

UNLESS OTHERWISE SPECIFIED DIMENSIONS ARE IN MILLIMETERS

FOR TOLERANCES NOT SPECIFIED USE:  
 [X mm ± 3 mm] [X.X mm ± .3 mm]  
 [X.XX mm ± .13 mm] ANGULAR ± 1°

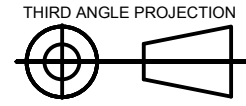

**PCTEL PROPRIETARY DATA**

THE INFORMATION AND/OR DRAWINGS CONTAINED IN THIS DOCUMENT IS CONFIDENTIAL AND PROPRIETARY TO PCTEL, INC. AND MAY NOT BE USED, REPRODUCED, IN WHOLE OR IN PART, OR MODIFIED IN ANY WAY WITHOUT THE EXPRESS WRITTEN PERMISSION OF AN AUTHORIZED REPRESENTATIVE OF PCTEL, INC.

DRAWN: CV DATE: 7/19/2017

CHECKED: \_\_\_\_\_ DATE: \_\_\_\_\_

MATERIAL: \_\_\_\_\_

FINISH: \_\_\_\_\_

PCTEL, INC.  
 471 BRIGHTON DRIVE  
 BLOOMINGDALE, IL 60108  
 PH. 630-372-6800  
 FAX. 630-372-8077

DESCRIPTION "G" MAG MOUNT, 12' RG58/U CABLE, NO CONNECTOR, CHROME

DRAWING NO. ODD\_GC-NC

SIZE B SCALE 1:1 SHEET 1 OF 1

4

3

2

1

NOTES: UNLESS OTHERWISE SPECIFIED

1. ALL MATERIALS SHALL BE ROHS COMPLIANT.
2. A (REF) DIMENSION IS FOR INFORMATION PURPOSES ONLY AND NO TOLERANCE IS IMPLIED.

REVISION HISTORY			
REV	DESCRIPTION	DATE	APPROVED
D	OUTLINE DIMENSIONAL DRAWING [C04557]	04MAR10	ML

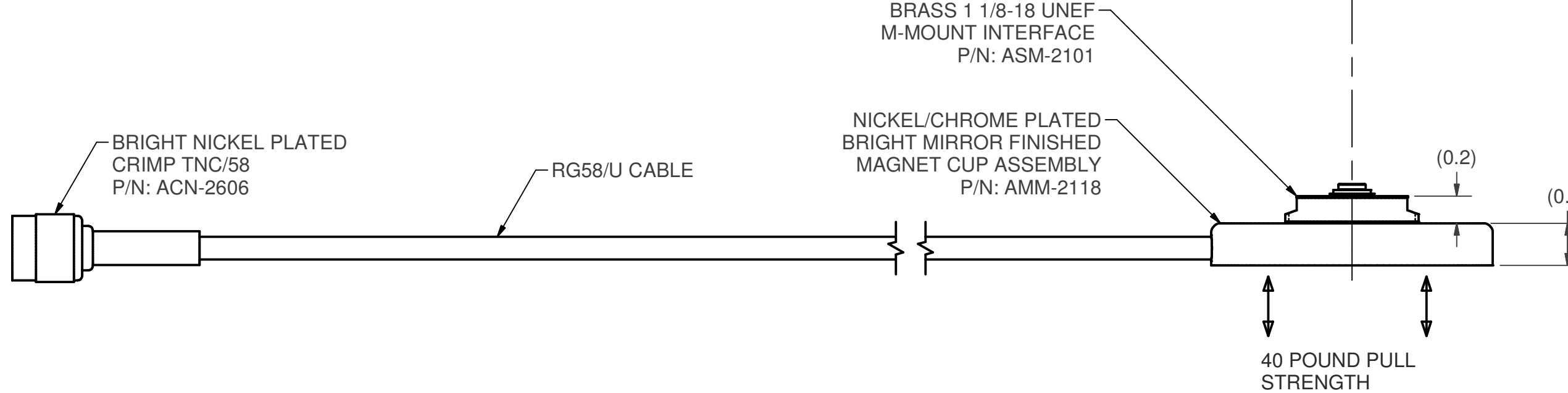
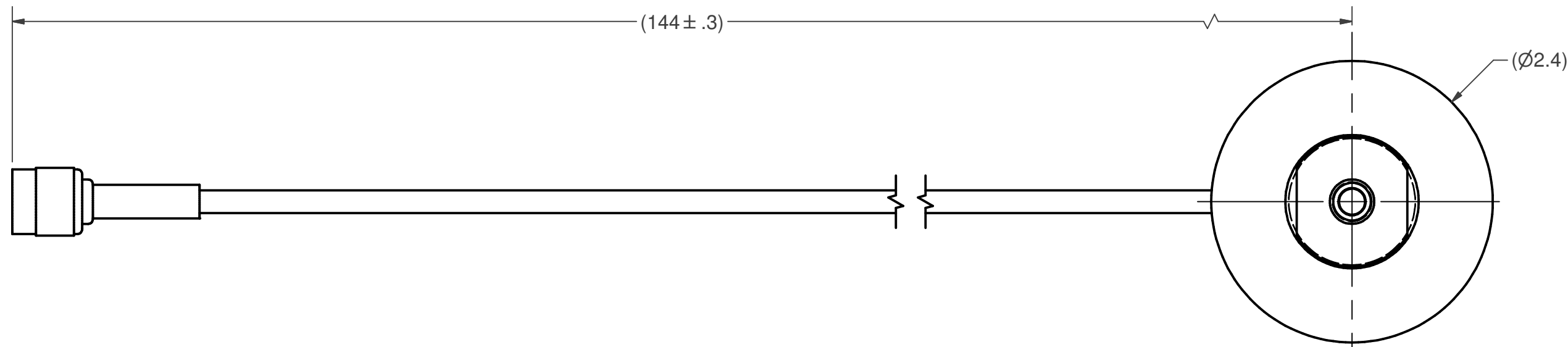

UNLESS OTHERWISE SPECIFIED DIMENSIONS ARE IN INCHES	DRAWN <b>IP</b>	DATE <b>8/31/2009</b>		PCTEL, INC. BROADBAND TECHNOLOGY GROUP 471 BRIGHTON DRIVE BLOOMINGDALE, IL 60108 PH. 630-372-6800 FAX. 630-372-8077
FOR TOLERANCES NOT SPECIFIED USE: X.X ± 0.1, X.XX ± 0.01, X.XXX ± 0.005 ANGULAR ± 2°	CHECKED	DATE		
THIRD ANGLE PROJECTION 	APPROVED	DATE		
PROPRIETARY DATA	MATERIAL: <b>SEE COMPONENT PRINTS</b>		DESCRIPTION	<b>GM, 12' 58U, CR TNC, CHR</b>
THE INFORMATION CONTAINED IN THIS DOCUMENT IS OF A PROPRIETARY NATURE. IT MAY NOT BE USED OR REPRODUCED WITHOUT EXPRESS WRITTEN PERMISSION OF PCTEL INC., BLOOMINGDALE, IL 60108	FINISH: <b>SEE COMPONENT PRINTS</b>		DRAWING NO.	<b>ODD_GMC</b>
	SIZE	B	SCALE	1:1
			SHEET	1 OF 1